



High Power Density



Wide Voltage Output



Parallel Capability



Universal AC Input



Regenerative Capability



Touch Panel



Regenerative AC Load

REGENERATIVE GRID SIMULATOR MODEL 61809/61812/61815

The Chroma 61800 series of 3U-high regenerative grid simulators offers three models with power ratings of 9kVA, 12kVA, and 15kVA, and includes single-phase and three-phase operation. With output voltage ranges up to 350V and 606V, each model can achieve 700V_{LN} with a single-phase 3-wire setup. Users can increase output power by configuring up to three units in parallel.

The Chroma 61809/61812/61815 models are regenerative, providing a complete energy-saving solution. The power generated by the DUT during the test can be efficiently fed back to the grid, rather than dissipated as heat, which protects the environment and lowers the cost of operation. With this capability, these models can be applied to renewable energy products such as PV inverters, energy storage systems (ESS), power conditioning systems (PCS), micro grids, power hardware-in-the-loop (PHIL), electric vehicle supply equipment (EVSE), onboard chargers (OBCs) bidirectional onboard chargers (BOBCs), and more.

The 61809/61812/61815 models are well-suited for regulatory test applications such as IEC 61000-3-2/-3-3/-3-11/-3-12 (AC voltage), IEEE 1547/IEC 62116 (green power generation), vehicle to grid (V2G), vehicle to load (V2L), vehicle to home (V2H), and energy storage systems (ESS).

By using full digital control technology, these models provide a maximum 350V_{LN} output voltage and 30Hz to 100Hz output frequency. The total harmonic distortion rate is less than 0.5% at full load and 50Hz/60Hz output frequency. In addition to AC output, a DC output mode and AC plus DC output mode is included, and can be expanded to DC test and AC test with DC bias voltage. The current output capability can provide 3 times the RMS peak current, which is suitable for a DUT input inrush current test.

These models also provide precision measurements such as RMS voltage, RMS current, true power, power factor, current crest factor, and many others. By applying advanced DSP technology, they can easily simulate power line disturbance (PLD) using List, Pulse and Step modes. Additional features such as waveform synthesis enable users to program various distorted harmonic waveforms required by regulatory standards.

The intuitive 5" LCD touchscreen allows users to quickly become familiar with operating the grid simulator. Standard remote interfaces include USB and LAN, with optional GPIB and CAN ports. The unit can be controlled via computer using Chroma's Softpanel software for fast digital operation. Chroma also provides control drivers that support system integration and application development in LabVIEW.



MODEL 61809/61812/61815

KEY FEATURES

- Output Power
61809: 9kVA
61812: 12kVA
61815: 15kVA
- Output voltage: 0-350V
- Output frequency: 30-100Hz/DC
- High Power Density: 15kVA in 3UH
- Intuitive touch panel interface
- User selectable single-phase or three-phase output
- Full rated apparent power sinking capability with regeneration back to grid at up to 89% efficiency
- Specifically designed for EV, PV inverter, and Smart Grid related test applications
- Programmable slew rate settings for voltage and frequency
- Programmable voltage and current limits
- Turn on, turn off phase angle control
- Synchronize TTL signal of voltage changing
- List, Pulse, Step mode functions for Power Line Disturbance (PLD) simulation
- Harmonics, inter-harmonics waveform synthesizer
- Comprehensive measurement capability, including current harmonics
- Response Speed adjustment function
- Universal AC input range
- Standard USB, LAN interfaces
- Optional GPIB, CAN interfaces
- Parallel output for higher power applications (single/three-phase)
- Supports series mode (single/three/split-phase)
- Programmable output impedance simulation*
- Regenerative AC load function (option)
- Stand-By fast response functionality
- Inductive/capacitive load simulation function
- Instant Load On capability
- Advanced load programming with List Mode*
- User-defined waveform load simulation*

* Only supported on FW 1.11 or later versions



Chroma
Advancing Excellence

HIGH POWER DENSITY

The Chroma 61809/61812/61815 models are high power density products within the 61800 regenerative grid simulator series. With advanced digital control systems and next-generation thermal management technology, they achieve up to 15kVA output power in a compact 3U chassis, while supporting a wide phase voltage range up to 350V_{LN}, single- or three-phase output modes, 100% DC output capability, and regenerative functionality. In addition, transient performance such as output voltage rise/fall time has been further enhanced, making this a breakthrough product in terms of power density - and delivering a truly next-gen power testing solution.

For system applications, the 3U form factor of the 61809/61812/61815 models occupies minimal rack space, providing users with greater flexibility and room for additional equipment. Compared to other products in the same power class, which are typically large, floor-standing units, the 61809/61812/61815 models can be conveniently placed on a benchtop, greatly improving ease of use in laboratory environments.

15kVA/3U

- Regenerative
- DC100%
- 1 or 3 Phase
- 350V_{LN} Range

INTUITIVE TOUCH SCREEN

Chroma 61809/61812/61815 models are equipped with a 5" LCD touchscreen interface, providing users with an intuitive UI for configuring and operating the unit. The rotary knob allows users to enlarge and fine-tune parameter settings with precision. The display can also be switched to full-screen measurement display mode, making key values easy to observe during operation.

1. Screen Lock
2. Display Mode
3. Rotary Knob Input Mode
4. Function Menu
5. 3-Phase Unified setting
6. Total Output Power
7. Output Switch On
8. Advanced Settings
9. Output Mode Selection
10. Output Voltage & Frequency Settings
11. Measurement
12. More Measurements (Swipe Right/Left)

More Setting

Off Degree Degree Immed

On Degree Off Degree

Vdc Off S/R V/ms Vac S/R V/ms

Freq. S/R Hz/ms Vdc S/R V/ms

Phase Angle 1-2 Phase Angle 1-3

Advanced Settings

Display Mode

	Ø1	Ø2	Ø3		
V	220.8 v	220.8 v	220.8 v		
I	10.35 A	10.84 A	10.11 A		
Po	2277.5 w	2385.4 w	2224.3 w		
V12	381.19 v	V31	381.21 v	S	6888.4 VA
V23	381.21 v	PoTotal	6887.2 w		

Display Mode

UNIVERSAL AC INPUT VOLTAGE RANGE

The 61809/61812/61815 models support a wide AC input voltage range and support three-phase input voltages ranging from 200V to 480V ± 10%. This makes them compatible with most three-phase systems commonly used worldwide, including 200V, 380V, 400V, and 480 grids.

FOUR-QUADRANT AC POWER OUTPUT

The Chroma Grid Simulators are fully 4-quadrant, regenerative, AC power sources designed for general-purpose electrical testing such as home appliances and industrial electronics needing a programmable AC input source. They are also ideal for simulating grid characteristics for testing PV inverters and on-line UPS systems. As shown below, the simulators can both source and sink power from the DUT seamlessly to support many different applications. In cases where the DUT supplies current back to the simulator, a detection circuit will sense the excess power and recycle it back to the grid.

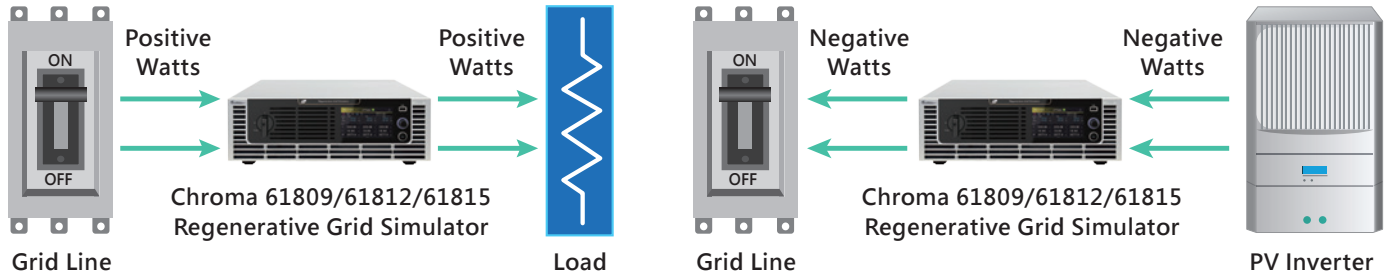

MASTER-SLAVE PARALLEL OUTPUT FUNCTION

The 61809/61812/61815 models support multi-unit parallel output using a master-slave configuration. A single unit serves as the master, while auxiliary units serve to increase overall output capacity. This setup allows up to 20 units*1 to be connected in parallel, delivering a maximum total output power of 300kVA. Both single-phase and three-phase output modes are supported in parallel operation, enabling users to scale up power for high-power testing.

In addition, Chroma offers dedicated parallel output cabinets*2 for the 61809, 61812, and 61815 models. These are ideal for applications requiring over 100kVA of AC power, providing a complete and reliable high-power solution.

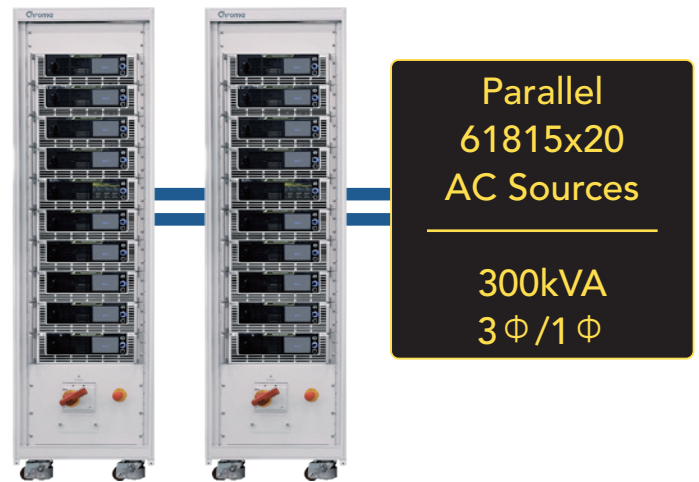

*1 Only supported on FW 1.11 or later versions.

*2 Call for detailed rack specifications.

MASTER-SLAVE SERIES CONNECTION FUNCTION

The Chroma 61815/61812/61809 models support a master-slave series connection of two units to deliver specialized high-voltage output. In this setup, the system can achieve AC line-to-neutral voltage up to 700V, AC line-to-line voltage up to 1212.4V, and DC voltage up to 989.8V. In AC source mode, it supports single-phase, three-phase, and split-phase operation. In split-phase mode, Chroma's unique hardware architecture enables the system to deliver up to 105A per phase using just two connected units. This offers an ideal solution for testing high-current bidirectional onboard chargers (BOBCs) designed to the 19.2kW mainstream in the U.S., requiring 80A per phase in a single-phase three-wire configuration.

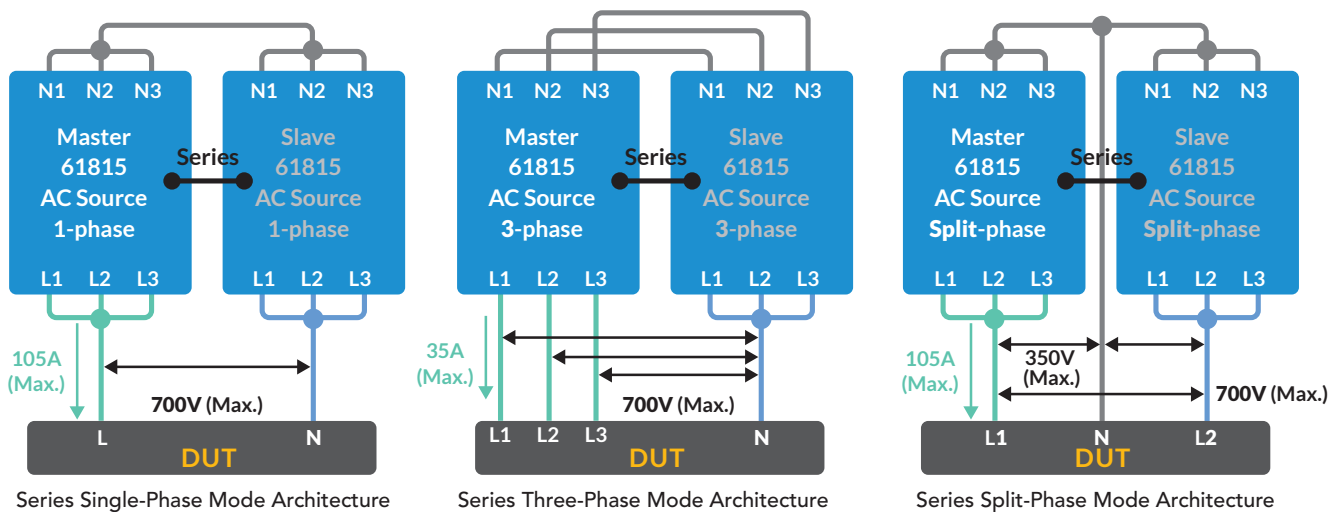

POWER LINE DISTURBANCE (PLD) FUNCTIONS

The Chroma 61809/61812/61815 models include advanced Power Line Disturbance (PLD) programming functions and can simulate various types of distorted voltage waveforms and transient conditions required for product validation. PLD functions include Step, Pulse, List modes, Synthesis, Inter-harmonic, and Harmonic Measurement. The Step and Pulse functions allow users to perform single or continuous step changes of output voltage. List mode is a versatile function that allows users to compose complex waveforms of up to 100 sequences. With these programming modes, voltage waveforms required by immunity specifications such as IEC 61000-4-11/-4-13/-4-14/-4-28 can be easily achieved.

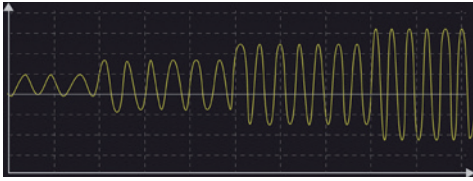

Step Mode

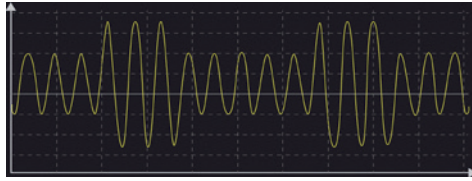

Pulse Mode

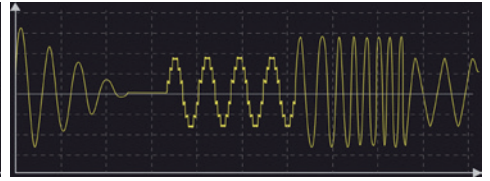

List Mode

These advanced programming modes can be easily configured via the touchscreen interface. For example, in List mode, users can view and edit all sequence settings directly on a single page, and use the search function to quickly locate specific steps if an adjustment is needed. The interface also supports intuitive, smartphone-like interactions, including convenient copy-and-paste functionality to streamline the programming process.

Advance >		3 Phase			Trigger
		List Mode			
Setting	Ø1	Ø2	Ø3		
Vac	220.0 V	220.0 V	220.0 V		
Freq.	60.00 Hz	60.00 Hz	60.00 Hz		
Meas.					
V	220.08 V	220.08 V	200.7 V		
I	10.35 A	10.84 A	10.11 A		
Po	2277.5 W	2385.4 W	2224.3 W		

Main Page of List Mode

SEQ No.	Vac (V) Start End	Vdc (V) Start End	F (Hz) Start End	Degree	Waveform	Time (ms)	SEQ No.
0	0.0 200.0	317.5 317.5	60.00 60.00	0.0	A	6.0	<<<
1	0.0 0.0	317.5 400.0	60.00 60.00	0.0	A	8.2	<<<
2	0.0 0.0	400.0 400.0	60.00 60.00	0.0	A	1.0	<<<
3	0.0 0.0	400.0 385.0	60.00 60.00	0.0	A	0.1	<<<

Sequence Editing Page of List Mode

The Synthesis function allows users to create periodic harmonic voltage waveforms up to the 50th order based on a 50/60Hz fundamental frequency. The Inter-harmonic function supports frequency sweeps ranging from 0.01Hz to 2400Hz on top of the 50/60Hz fundamental frequency. This special function assists users in locating resonance points. Additionally, the Harmonic Measurement function can measure voltage or current harmonics up to the 50th order and display values such as fundamental voltage, DC component, and total harmonic distortion (THD).

N	%	θ	N	%	θ	N	%	θ
2	0.00	0.0	3	2.30	0.0	4	0.00	0.0
5	0.00	0.0	6	9.8	0.0	7	0.00	0.0
8	15.80	0.0	9	2.5	0.0	10	0.00	0.0
11	0.00	0.0	12	0.00	0.0	13	0.00	0.0
14	0.00	0.0	15	0.00	0.0	16	0.00	0.0

Synthesis

Vac fund: 100.0 V

F fund: 60.00 Hz

Vdc: 0.0 V

Degree: 0.0

Synthesis Function

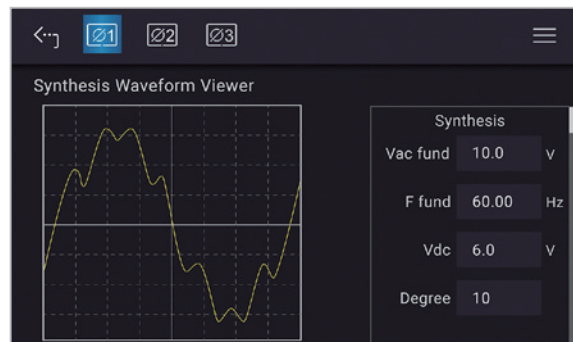

Waveform Viewer of the Synthesis Function

Inter-Harmonic Waveform Setting	
F Start	0.0 Hz
F End	0.0 Hz
Time	0.0 Sec
Level	0.0 %

Inter-harmonic Function

Advance >		3 Phase			Trigger
		Harmonic Meas.			
N	%	N	%	N	%
2	0.00	3	0.03	4	2.53
5	0.00	6	1.94	7	0.00
8	2.61	9	0.03	10	0.00
11	0.01	12	0.00	13	0.00
14	0.00	15	0.00	16	0.00

Harmonic Meas.

THD: 0.0 %

DC: 60.00 V

Fund.: 0.0 Hz

Harmonic Measurement Function

RESPONSE SPEED ADJUSTMENT FUNCTION

AC testing often involves matching the characteristics of the power source to those of the DUT, which can vary significantly depending on transient or stability performance requirements. To address this, the Chroma 61809/61812/61815 models introduce a new Response Speed function that allows users to adjust the power output via a precision digital control algorithm that alters the system's response bandwidth. Three modes are selectable: Fast (optimized for transient performance), Medium, and Slow (optimized for stability). With a single press, users can tailor the AC source output characteristics to best match the needs of different DUTs and test scenarios.

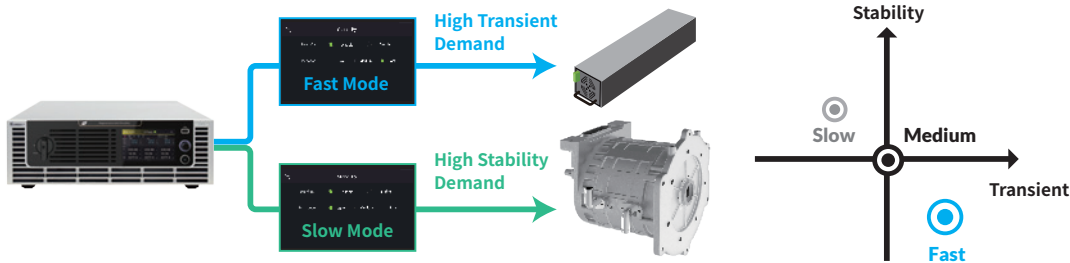

PROGRAMMABLE OUTPUT IMPEDANCE FUNCTION

The 61809/61812/61815 models feature a programmable output impedance function*, allowing users to simulate a reference impedance Z by specifying virtual output resistance (R) and inductance (L) values. Based on the resulting load current, the system produces a corresponding voltage drop, making it suitable for simulating the voltage drop conditions required in flicker tests under standards such as IEC 61000-3-3 and IEC 61000-3-11.

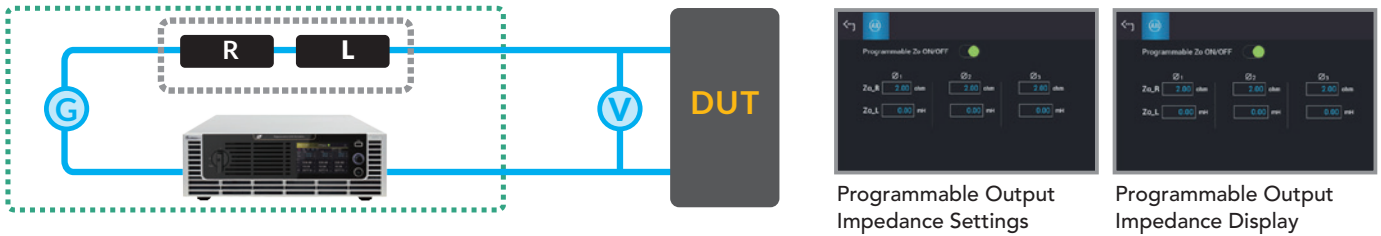

* Only supported on FW 1.11 or later versions.

* This function only supports single unit operation (three-phase mode only), and does not support parallel operation.

ELECTRIC VEHICLE TEST APPLICATIONS

The 61809/61812/61815 models offer complete power testing solutions for EV-related products such as electric vehicle supply equipment (EVSE) and onboard chargers (OBCs). They are compliant with EVSE testing standards including SAE J1772 (AC Level 1 and 2) as well as China's QC/T 895 standard for OBC testing. As OBC development increasingly moves toward bi-directional charge and discharge applications like V2G (Vehicle to Grid), V2L (Vehicle to Load) and V2H (Vehicle to Home), these models are ideally suited for such testing needs. Equipped with regenerative functionality, optional AC load capabilities, and advanced PLD programming features, they offer full support for bi-directional onboard charger (BOBC) test applications.

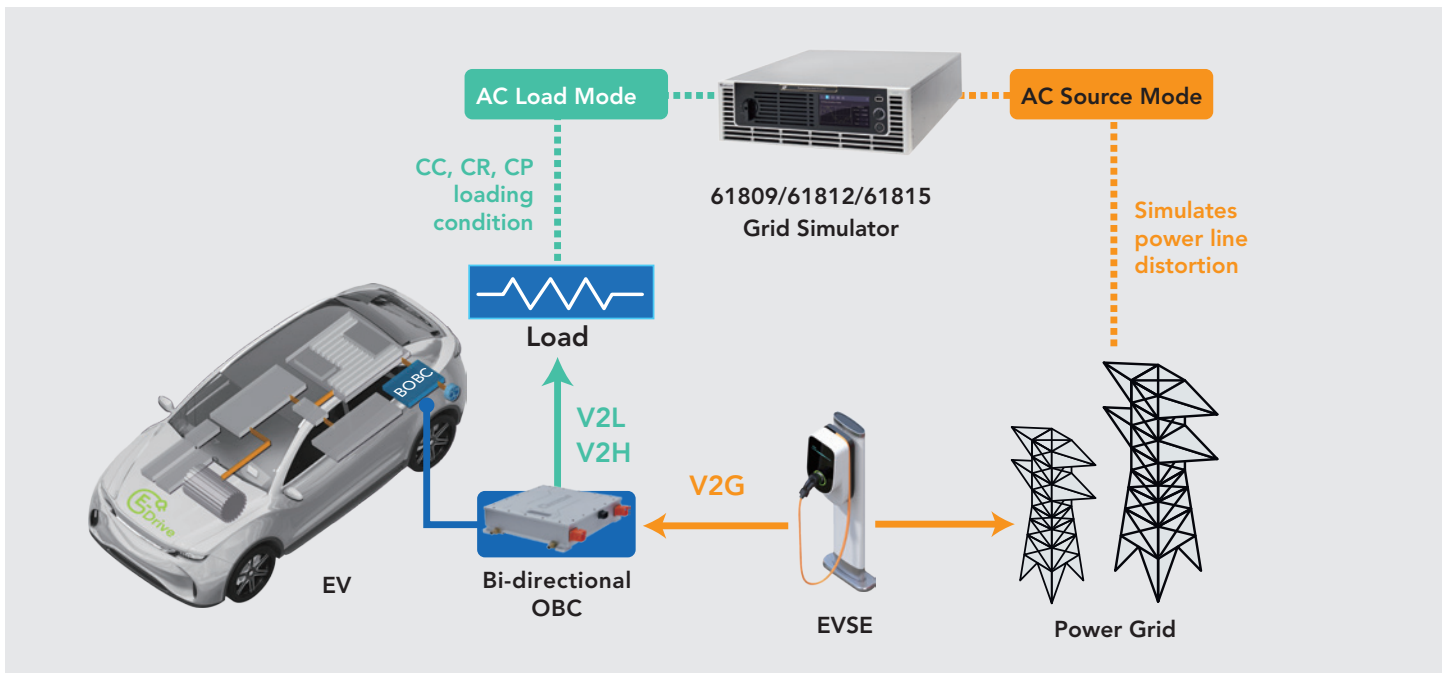

AC LOAD – REGENERATIVE AC LOAD FUNCTION

The Chroma 61809/61812/61815 models can be optionally equipped with the B618007 regenerative AC load function, enabling the system to recover energy even while operating in AC load mode and perform full 4-quadrant loading. Designed to simulate various types of real-world loads—including resistive, rectified, inductive, and capacitive ones - the function offers seven selectable load modes to cover a wide range of test applications. In addition, the system features advanced load functions like user-defined waveforms, List mode, Stand-By mode, half-cycle loading, Instant Load On, and Response Speed adjustment, providing users with a versatile toolset for dynamic and precise load simulation.

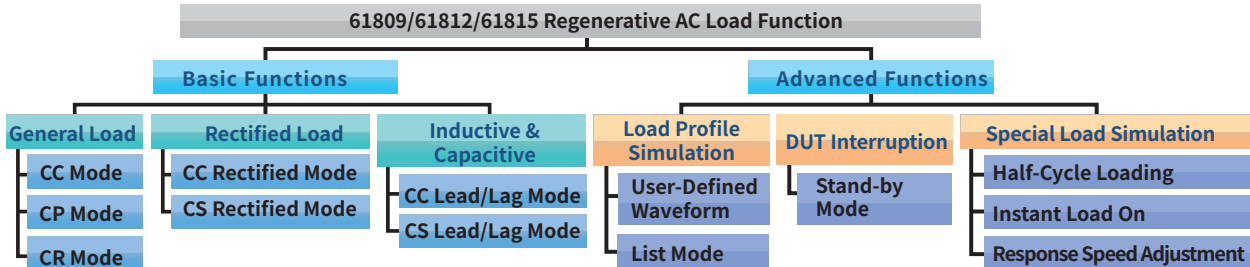

GENERAL LOAD

General load simulation supports Constant Current (CC), Constant Power (CP), and Constant Resistance (CR) modes. In CC and CP modes, users can set the power factor (PF) or crest factor (CF) of the load, and also use the Priority setting to define which parameter takes precedence when both are set simultaneously. In CR mode, the PF is fixed at 1, making it ideal for simulating linear impedance that responds quickly to voltage changes, such as for voltage interruption load testing.



CC Mode Main Page (Three-Phase)

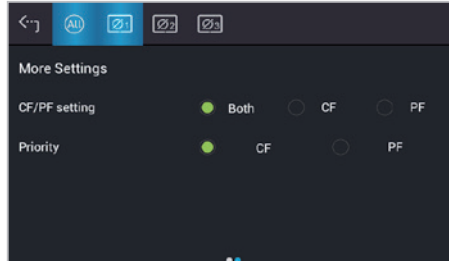

CF/PF Parameter Priority Settings



Voltage Interruption Load Test in CR Mode

RECTIFIED LOAD

The CC Rectified and CS Rectified modes are designed to simulate rectified or nonlinear loads, such as traditional inverters, UPS systems, rectifier switches, lighting and audio equipment with power control, and motor-driven devices with variable frequency drives. Depending on whether CC or CS testing is required, users can additionally set the crest factor (CF) to generate sharp current peaks. Combined with high-stability slew rate control, these modes enable precise simulation of various non-sinusoidal current waveforms.



CC Rectified Mode Main Page (Three-Phase)

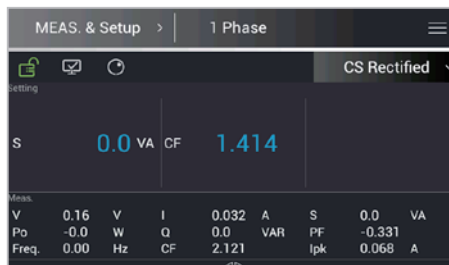

CS Rectified Mode Main Page (Single-Phase)



Rectified Mode (CF = 3)

INDUCTIVE AND CAPACITIVE LOAD

The CC Lead/Lag and CS Lead/Lag modes allow users to simulate inductive or capacitive load characteristics by introducing a phase shift degree (Deg) between current and voltage under constant current or constant apparent power conditions. By setting the current to lead or lag the voltage, these modes accurately reproduce the behavior of real-world equipment affected by passive components.



CC Lead/Lag Mode Main Page (Three-Phase)

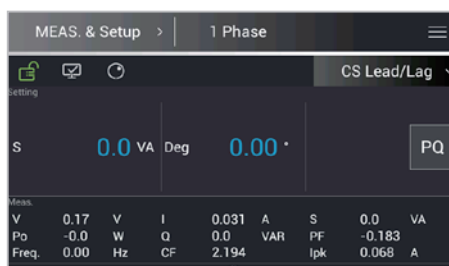

CS Lead/Lag Mode Main Page (Single-Phase)

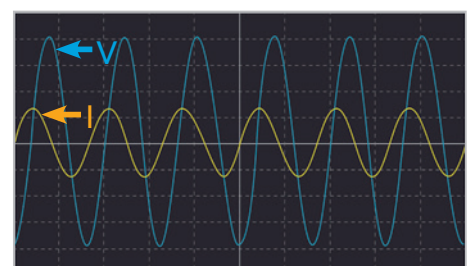

Lead/Lag Mode (Deg = 90°)

AC LOAD – USER-DEFINED WAVEFORM FUNCTION

To replicate real-world load current behavior, the Chroma 61809/61812/61815 models feature a user-defined waveform (UDW) function* in AC load mode. This function allows users to capture current waveforms and data using an oscilloscope and store them in the instrument via the SoftPanel software's User Waveform feature. These stored waveforms can then be reproduced during load testing, providing targeted scenario simulations for voltage-source DUTs. The UDW function is especially useful for simulating diverse load characteristics in automotive applications, such as BOBCs and inverters for V2L testing.

The UDW function supports two modes: VAL and PU, each allowing storage and use of up to 200 waveforms. In VAL mode, the 61809/61812/61815 models replicate the actual current waveform exactly as captured. In PU mode, the waveform shape is normalized and scaled according to the user-specified peak current level. Additionally, users can manually edit current waveforms in Excel by defining one complete cycle (typically 1024 points) of current data. This custom waveform can then be imported into the 61809/61812/61815 models for flexible, scenario-based load testing.

* Only supported on FW 1.11 or later versions.

* Not supported in Split Phase mode.

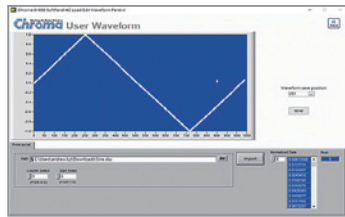

SoftPanel - User Waveform function



Chroma 61815
Regenerative AC load mode

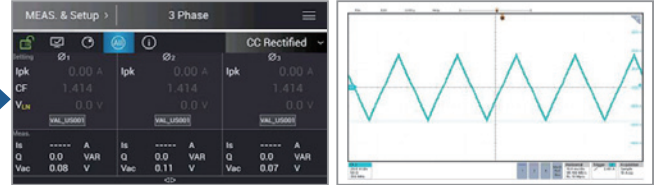

In VAL mode, the imported waveform is fully reproduced.



In PU mode, the peak current can be set by the user.

AC LOAD: LIST MODE ADVANCED PROGRAMMING FUNCTION

In AC load mode, the Chroma 61809/61812/61815 models support advanced programming functionality via List Mode*. Users can define up to 100 individual sequences to create a continuous, programmable load profile. Each sequence can be configured independently, with the option to control execution duration based on either a fixed time or a specified number of load cycles, allowing flexible combinations for dynamic load simulation. In List Mode, the initial sequence allows editing of the starting load phase angle, while subsequent sequences automatically follow the phase and angle of the voltage source. This design simplifies the creation of dynamic current waveforms that respond to changing load conditions in real-time.

* Only supported on FW 1.11 or later versions.

* Not supported in Split Phase mode.

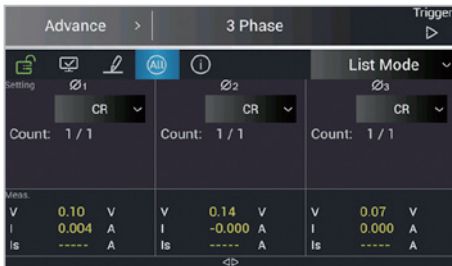

List Mode Main Page

Seq No.	S	CF	PF	Phase	On Degree	Waveform	Cycle	SEQ No.
0	200.0	0000.0	60.00	Lead	0.0	SINE	1Cycle	4
1	200.0	0000.0	60.00	Lag	0.0	SINE	1Cycle	
2	200.0	0000.0	60.00	Lead	0.0	SINE	1Cycle	
3	200.0	0000.0	60.00	Lead	0.0	SQUA	1Cycle	

List Mode Editing Page

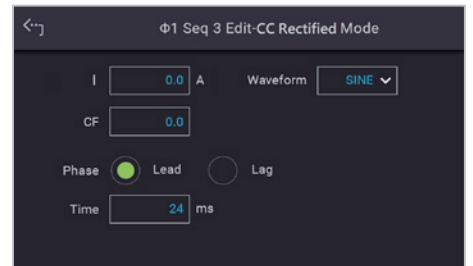

Sequence Editing Page

When using CC Rectified Mode within List Mode, users can select from various load waveform shapes for each sequence, including sine wave, half-cycle wave, and user-defined waveforms (UDW). For UDW applications, an oscilloscope can be used to capture a complete segment of dynamic load current data. From this data, one cycle of each key waveform can be extracted and imported into the instrument individually. These waveforms can then be arranged across multiple sequences using List Mode, allowing users to reconstruct the original full waveform captured by the oscilloscope as a continuous, programmable sequence.



List Mode Load Waveform Composed of Multiple Current Types

This functionality is particularly suited for dynamic load testing and performing V2L simulation for automotive products by reproducing the current characteristics of real household appliances.

AC Load – HALF-CYCLE LOADING FUNCTION

The regenerative AC load option provides a half-cycle loading function via CC Rectified Mode. It can provide positive half-cycle, negative half-cycle, and 90° leading or trailing edge loading to simulate the switching characteristics of SCRs or TRIACs. Typical applications include simulating the load behavior of household appliances with temperature or lighting control, evaluating protection switches, testing induction motor characteristics, and verifying the output stability of voltage sources.



Half-Cycle Function

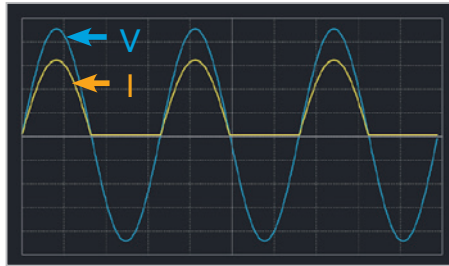

Positive Half-Cycle Loading Review

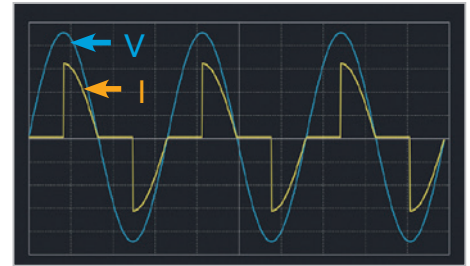

90° Leading Edge Loading Review

AC LOAD – STAND-BY FAST RESPONSE FUNCTIONALITY

In AC load mode, the Chroma 61809/61812/61815 models incorporate a new Stand-By function, enabled by advanced control algorithms and fast, precise detection circuits. This feature is designed for testing scenarios where the DUT is suddenly disconnected or the voltage source is momentarily interrupted. When a voltage drop is detected, the system rapidly switches to standby mode to prevent open-circuit conditions on the current source. Without this function, a switching load may not respond in time to the voltage drop and could generate a reverse bouncing peak voltage, triggering overvoltage protection and interrupting the test process. In addition, the new Instant Load On function (Load On IMMED.) allows the load to engage immediately as soon as the voltage source is activated, which enables load startup testing with near-zero delay. Users simply configure the load settings and activate Load On, after which the source can be interrupted or resumed at any point during the test. These features make the 61809, 61812, and 61815 ideal for AC EVSE testing, including dynamic load testing, OCP/OPP load testing, card-swipe charging tests, as well as standby startup and backup switching tests for inverters and UPS systems.

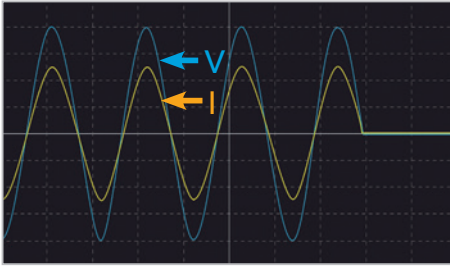

Voltage Source Interruption Test



Load On IMMED. Function Toggles

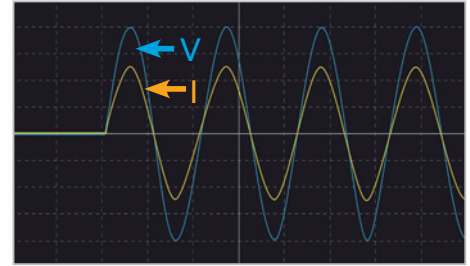

Fast Standby Startup Loading Test

AC LOAD – RESPONSE SPEED ADJUSTMENT FUNCTION

In AC load mode, the Chroma 61809/61812/61815 models offer high versatility through a Response Speed adjustment feature, enabled by a precision digital control algorithm that arranges the system response bandwidth. Users can simply switch between different load response types with a single setting, adapting the load behavior to suit a wide range of AC voltage-source DUTs. When testing voltage sources with high harmonic content, the Slow mode (designed for distorted voltage sources) delivers stable load performance and is well-suited for early development stages, when the voltage waveform may not yet meet standard sinewave criteria. Conversely, during later stages of voltage source development where precise current waveform control is essential, Fast mode enables highly accurate current loading. This is ideal for applications such as rectified load simulation, phase-leading/lagging loads, half-cycle loading, user-defined waveform loading, and zero-delay startup loading.

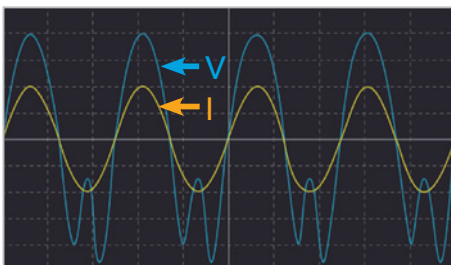

Slow Mode provides great tolerance for distorted voltage sources

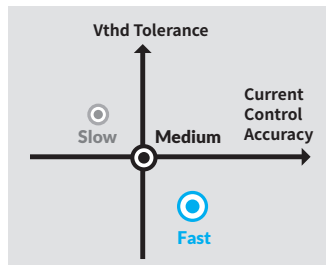

Fast Mode provides high current control accuracy

AC LOAD – MASTER-SLAVE PARALLEL FUNCTION

In AC load mode, the Chroma 61809/61812/61815 models support a master-slave parallel configuration of up to ten units, with one master controlling the other auxiliary units. This setup enables a maximum total AC load capacity of 150 kVA in three-phase mode for high-power testing needs. In addition, the AC load mode supports series connection* of two standalone units to enable split phase load applications. This configuration is designed for single-phase-three-wire (split phase) system and can deliver up to 105A of load current per line, making it ideal for testing 19.2kW on-board chargers with 80A per line in a split phase configuration.

* Only supported on FW 1.11 or later versions.

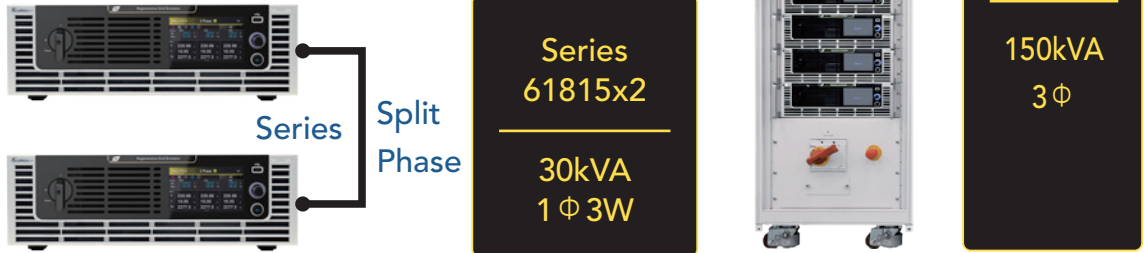

AC BOBC TEST SOLUTION FOR EU/US MARKETS

Current mainstream AC BOBC products are designed for different power specifications across regions. In Europe, the standard is 22kW at 380V line voltage with three-phase distribution, while in the U.S. it is 19.2kW at 240V / 120V with split-phase distribution. To address these complex power specifications and wiring configurations, two Chroma 61815 units can be paired with a dedicated Wire Connection Box*. Through the master unit interface, users can automatically switch between different equipment modes and wiring setups such as AC source/load modes, series/parallel, and output modes including single-phase, three-phase, and split-phase.

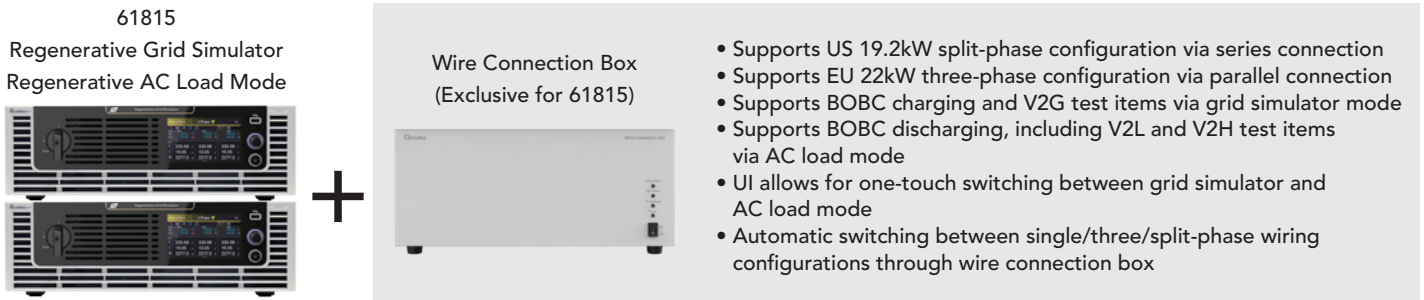

For split-phase testing of 19.2kW BOBCs in a split-phase setup, each line may require up to 80A of current. For AC power products under 20kVA on the market, it is necessary to connect three units in parallel and take two phases of them to implement this high current requirement. In contrast, the Chroma 61815 can achieve up to 105A per line using just two units in series through its unique split-phase architecture, supporting both AC source and AC load modes for a more economical BOBC test solution.

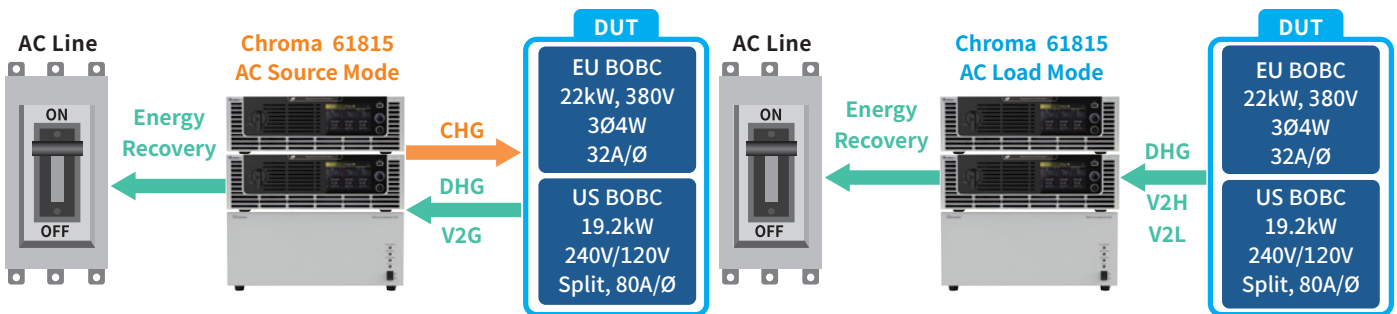

For V2G, V2H, or V2L test applications, the Chroma 61815 supports both AC source and AC load modes, and utilizes its regenerative functionality to return energy from the BOBC power testing without impacting the facility's power grid. This energy recovery capability can reduce test power consumption by up to 89%, significantly improving overall efficiency, minimizing energy waste, and lowering operating costs, resulting in a more sustainable and cost-effective AC test solution for BOBC systems.

* The dedicated wire connection box for the 61815 (ITM-0354721) is available as an optional accessory. Please contact your Chroma representative for details.

SPECIFICATIONS

Model	61809	61812	61815
AC Output Rating			
Output Phase	1 or 3 selectable	1 or 3 selectable	1 or 3 selectable
Max. Power	9kVA	12kVA	15kVA
Per Phase	3kVA	4kVA	5kVA
Voltage			
Range	0-350V _{LN} / 0-606V _{LL}	0-350V _{LN} / 0-606V _{LL}	0-350V _{LN} / 0-606V _{LL}
Setting Accuracy	0.1%+0.2% F.S.	0.1%+0.2% F.S.	0.1%+0.2% F.S.
Resolution	0.1V	0.1V	0.1V
Distortion	< 0.5% @ 50/60Hz < 0.8% @ 30-100Hz	< 0.5% @ 50/60Hz < 0.8% @ 30-100Hz	< 0.5% @ 50/60Hz < 0.8% @ 30-100Hz
Line Regulation	0.10%	0.10%	0.10%
Load Regulation	0.20%	0.20%	0.20%
Maximum Current (1-phase mode)			
RMS	87A	96A	105A
Peak	261A	288A	315A
Maximum Current (each phase in 3-phase mode)			
RMS	29A	32A	35A
Peak	87A	96A	105A
Frequency			
Range	30-100Hz	30-100Hz	30-100Hz
Accuracy	0.01%	0.01%	0.01%
DC Output (1-phase mode)			
Power	9kW	12kW	15kW
Voltage	495V	495V	495V
Maximum Current	65.25A	72A	78.75A
DC Output (each phase in 3-phase mode)			
Power	3kW	4kW	5kW
Voltage	495V	495V	495V
Maximum Current	21.75A	24A	26.25A
Harmonic Synthesis Function			
Harmonic Range	up to 50 Harmonic order @ 50/60Hz fundamental frequency		
Input Rating			
Voltage Operating Range	3 Φ 200V-220V \pm 10%V _{LL} /47-63Hz (100% output power) 3 Φ 380V-480V \pm 10%V _{LL} /47-63Hz (100% output power)		3 Φ 200V-220V \pm 10%V _{LL} /47-63Hz (80% output power) 3 Φ 380V-480V \pm 10%V _{LL} /47-63Hz (100% output power)
Current	39A Max./Phase (3 Φ 200-240V \pm 10%V _{LL}) Max. 21A/Phase (3 Φ 380-480V \pm 10%V _{LL})	51A Max./Phase (3 Φ 200-240V \pm 10%V _{LL}) Max. 27A/Phase (3 Φ 380-480V \pm 10%V _{LL})	51A Max./Phase (3 Φ 200-240V \pm 10%V _{LL}) Max. 34A/Phase (3 Φ 380-480V \pm 10%V _{LL})
Power Factor	0.98 (Typical)	0.98 (Typical)	0.98 (Typical)
Measurement			
Voltage			
Range	0-350V _{LN}	0-350V _{LN}	0-350V _{LN}
Accuracy	0.1%+0.2% F.S.	0.1%+0.2% F.S.	0.1%+0.2% F.S.
Current			
Range (Peak)	261A	288A	315A
Accuracy (RMS)	0.4%+0.3% F.S.	0.4%+0.3% F.S.	0.4%+0.3% F.S.
Accuracy (Peak)	0.4%+0.6% F.S.	0.4%+0.6% F.S.	0.4%+0.6% F.S.
Power			
Accuracy	0.4%+0.4% F.S.	0.4%+0.4% F.S.	0.4%+0.4% F.S.
Others			
Parallel Function*1	Max. 20 units		
Series Function	Max. 2 units		
Programmable Impedance*1	0.00 Ω +0.40mH to 2.00 Ω +4.00mH (each phase)		
Energy Saving Function	Sleep Mode		
Efficiency	89%		
Protection	OVP, OCP, OPP, OTP, FAN		
Safety & EMC	CE (includes EMC & LVD)		
Dimensions (H x W x D)	132.8 x 428 x 700 mm/5.23 x 16.85 x 27.55 inch		
Weight	50 kg/110 lbs	50 kg/110 lbs	50 kg/110 lbs

*1: Only supported on FW 1.11 or later versions.

* All specifications are subject to change without notice.

SPECIFICATIONS – Regenerative AC Load B618007

Optional AC Load Function	61809	61812	61815
Operating (each phase)			
Phase	1 or 3 selectable	1 or 3 selectable	1 or 3 selectable
Power	9kVA	12kVA	15kVA*1
Current (RMS)	87A	96A	105A
Current (Peak)	261A	288A	315A
Voltage Range	30-350V	30-350V	30-350V
Frequency Range	30-100Hz	30-100Hz	30-100Hz
CC Mode (each phase)			
Current Range (RMS)	0-29A	0-32A	0-35A
Accuracy*2	0.3%+0.5% F.S.	0.3%+0.5% F.S.	0.3%+0.5% F.S.
Resolution	0.01A	0.01A	0.01A
Crest Factor Range	1.414-3.000	1.414-3.000	1.414-3.000
PF Range	0.100-1.000 (Lead or Lag)	0.100-1.000 (Lead or Lag)	0.100-1.000 (Lead or Lag)
CP Mode (each phase)			
Power Range	0-3kW	0-4kW	0-5kW*1
Accuracy	0.3%+0.3% F.S.	0.3%+0.3% F.S.	0.3%+0.3% F.S.
Resolution	1W	1W	1W
Crest Factor Range	1.414-3.000	1.414-3.000	1.414-3.000
PF Range	0.100-1.000 (Lead or Lag)	0.100-1.000 (Lead or Lag)	0.100-1.000 (Lead or Lag)
CR Mode (each phase)			
Resistance Range	1Ω-300Ω	1Ω-300Ω	1Ω-300Ω
Accuracy (Ω)	0.3% + 0.5%F.S.	0.3% + 0.5%F.S.	0.3% + 0.5%F.S.
Resolution (Ω)	0.001Ω	0.001Ω	0.001Ω
CC Rectified Mode (each phase)			
Current Range (RMS)	0-29A	0-32A	0-35A
Accuracy*2	0.3%+0.5% F.S.	0.3%+0.5% F.S.	0.3%+0.5% F.S.
Resolution	0.01A	0.01A	0.01A
Crest Factor Range	1.414-3.000	1.414-3.000	1.414-3.000
CS Rectified Mode (each phase)			
Power Range	0-3kVA	0-4kVA	0-5kVA*1
Accuracy	0.3% + 0.3%F.S.	0.3% + 0.3%F.S.	0.3% + 0.3%F.S.
Resolution	1VA	1VA	1VA
Crest Factor Range	1.414-3.000	1.414-3.000	1.414-3.000
CC Phase Lead/Lag Mode (each phase)			
Current Range (RMS)	0-29A	0-32A	0-35A
Accuracy*2	0.3% + 0.5%F.S.	0.3% + 0.5%F.S.	0.3% + 0.5%F.S.
Resolution	0.01A	0.01A	0.01A
Phase Degree Range	-90° to +90° (Current Source Mode: +90.01° to +180° & -90.01° to -180°)		
CS Phase Lead/Lag Mode (each phase)			
Power Range	0-3kVA	0-4kVA	0-5kVA*1
Accuracy	0.3% + 0.3%F.S.	0.3% + 0.3%F.S.	0.3% + 0.3%F.S.
Resolution	1VA	1VA	1VA
Phase Degree	-84.26° - +84.26°	-84.26° - +84.26°	-84.26° - +84.26°
PF Range	0.100-1.000 (Lead or Lag)	0.100-1.000 (Lead or Lag)	0.100-1.000 (Lead or Lag)
Measurement			
Voltage			
Voltage Range	0-350V	0-350V	0-350V
Accuracy	0.1%+0.2%F.S.	0.1%+0.2%F.S.	0.1%+0.2%F.S.
Current			
Current Range (Peak)	0-261A	0-288A	0-315A
Accuracy (RMS)	0.4%+0.3% F.S.	0.4%+0.3% F.S.	0.4%+0.3% F.S.
Accuracy (Peak)	0.4%+0.6% F.S.	0.4%+0.6% F.S.	0.4%+0.6% F.S.
Power			
Accuracy	0.4%+0.8% F.S.	0.4%+0.8% F.S.	0.4%+0.8% F.S.
Input Rating			
Voltage Operating Range	3Φ 200V-220V ± 10%V _{LL} / 47-63Hz (100% output power) 3Φ 380V-480V ± 10%V _{LL} / 47-63Hz (100% output power)		3Φ 200V-220V ± 10%V _{LL} / 47-63Hz (80% output power) 3Φ 380V-480V ± 10%V _{LL} / 47-63Hz (100% output power)
Current	39A max./phase (3Φ 200-240V ± 10%V _{LL}) 21A max./phase (3Φ 380V-480V ± 10%V _{LL})	51A max./phase (3Φ 200-240V ± 10%V _{LL}) 27A max./phase (3Φ 380V-480V ± 10%V _{LL})	51A max./phase (3Φ 200-240V ± 10%V _{LL}) 34A max./phase (3Φ 380V-480V ± 10%V _{LL})
Power Factor	0.98 (Typical)	0.98 (Typical)	0.98 (Typical)
Others			
Parallel Function*3	Max. 10 units		
Series Function*4	Max. 2 units		
Instant Load On	Load On IMMED. Function*5 (min. delay time <0.1μs)		
Load Profile Simulation*4	List Mode, User Defined Waveform (UDW)		
Energy Saving Function	Sleep Mode		
Efficiency	89%		
Protection	OVP, OCP, OPP, OTP, FAN		
Safety & EMC	CE (includes EMC & LVD)		

*1: The output power will be derated to 80% when using 3Φ 200Vac-220Vac as input voltage.

*2: Condition to meet specification: I_{rms} ≥ 0.5A and the DUT source is a defined sinusoidal voltage. (V_{thd} < 0.5% @ 50Hz/60Hz, CF=1.414)

*3: In AC load mode, 61815/61812/61809 only supports 3-phase mode in parallel.

*4: Only supported on FW 1.11 or later versions.

*5: The Load On IMMED. function is only available in CC Rectified and CR mode.

* All specifications are subject to change without notice.

SOFTPANEL

The 61800 series Softpanel software is designed specifically for users to control the regenerative grid simulator with a user friendly interface in a graphical, instrument-like setting. Users can perform online and offline waveform editing, and the Softpanel provides a test environment configured specifically for conducting regulatory tests like IEC 61000-4-11, 4-13, 4-14, and 4-28.

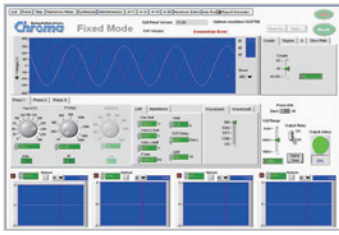

Main Operation Menu

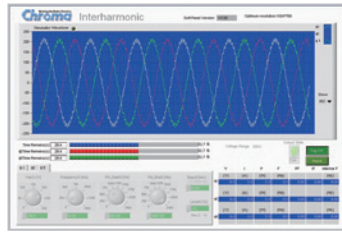

Inter-harmonic Test



Transient Voltage Programming

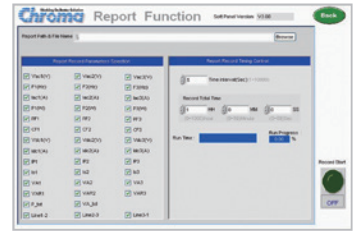

Recording Function

PANEL DESCRIPTION

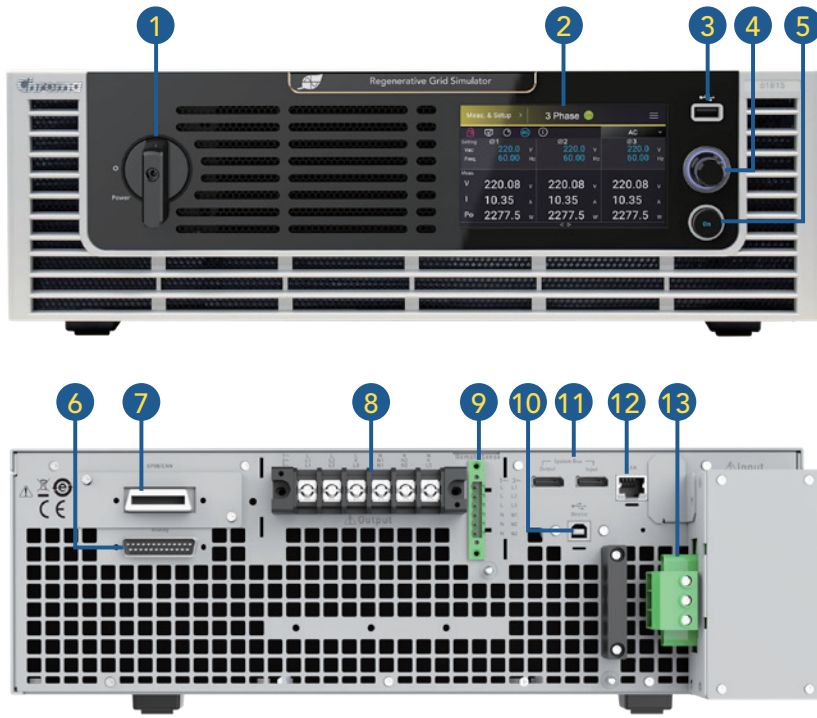

1. Power ON/OFF Switch
2. 5" LCD Touch Panel
Displays: measurements, setup, control, and status
3. USB HOST
Screenshot, save / recall the setting parameters
4. Pushable Rotary Knob
Rotate to edit screen and set values; push to change setting digits
5. Output ON/OFF Key
Press the ON key: light indicates Output ON, dark indicates Output OFF
6. Analog Programming Interface (Ext. V Reference/TTL I/O Port)
External analog signal for voltage control and signal for system integration
7. GPIB/CAN Shared Slot (alternative installation)
8. AC Output Terminal
9. Remote Sense Terminal
10. USB Interface (standard)
11. System Bus
For master-slave parallel output function
12. LAN Interface (standard)
13. AC Input Terminal

ORDERING INFORMATION

- 61809: Regenerative Grid Simulator 9kVA
- 61812: Regenerative Grid Simulator 12kVA
- 61815: Regenerative Grid Simulator 15kVA
- A618001: Softpanel for 61800 Series
- A618005: Single/Three Phase Switching Unit (option)
- A620039: GPIB remote interface (option)
- A620045: CAN remote interface (option)
- B618007: Regenerative AC Load (option)

Get more product & global distributor information in th Chroma ATE APP

iOS



Android

Search Keyword

61815

HEADQUARTERS
CHROMA ATE INC.
88 Wenmao Rd.,
Guishan Dist.,
Taoyuan City
333001, Taiwan
T +886-3-327-9999
F +886-3-327-8898
www.chromaate.com
info@chromaate.com

U.S.A.
CHROMA SYSTEMS
SOLUTIONS, INC.
19772 Pauling,
Foothill Ranch,
CA 92610
T +1-949-600-6400
F +1-949-600-6401
www.chromausa.com
sales@chromausa.com

EUROPE
CHROMA ATE EUROPE B.V.
Morsestraat 32, 6716 AH
Ede, The Netherlands
T +31-318-648282
F +31-318-648288
www.chroma.eu.com
salesnl@chroma.eu.com

CHROMA GERMANY GMBH
Südtiroler Str. 9, 86165,
Augsburg, Germany
T +49-821-790967-0
F +49-821-790967-600
www.chroma.eu.com
salesde@chroma.eu.com

JAPAN
CHROMA JAPAN
CORP.
888 Nippa-cho,
Kouhoku-ku,
Yokohama-shi,
Kanagawa,
223-0057 Japan
T +81-45-542-1118
F +81-45-542-1080
www.chroma.co.jp
info@chroma.co.jp

KOREA
CHROMA ATE
KOREA BRANCH
312, Gold Tower,
14-2, Pangyoeyeok-ro
192, Bundang-gu,
Seongnam-si,
Gyeonggi-do,
13524, Korea
T +82-31-781-1025
F +82-31-8017-6614
www.chromaate.co.kr
info@chromaate.com

CHINA
CHROMA ELECTRONICS
(SHENZHEN) CO., LTD.
8F, No.4, Nanyou Tian
An Industrial Estate,
Shenzhen, China
T +86-755-2664-4598
F +86-755-2641-9620
www.chroma.com.cn
info@chromaate.com

SOUTHEAST ASIA
QUANTEL PTE LTD.
(A company of Chroma Group)
25 Kallang Avenue #05-02
Singapore 339416
T +65-6745-3200
F +65-6745-9764
www.quantel-global.com
sales@quantel-global.com